

**AUTOMATIC
WINCH**

BREAKS ALL BARRIERS.

Pinotti[®]

PERFECT SLOPES AT LIGHTNING SPEED.



In extreme alpine situations, a winch is essential. Power and maneuverability are the key ingredients on steep terrain or when moving large amounts of snow. The AUTOMATIC winch from PRINOTH features both. Precisely and efficiently winding up or winding out the winch is easy thanks to a hydraulic winding system, a feature which contributes to extended cable service life. This, in combination with the drum winch concept, is truly a well-rounded idea.

THE UPPER HAND WITH PRINOTH

The AUTOMATIC winch has two primary advantages: Efficiency and safety. After all, only the correct attachments will provide the desired value. PRINOTH's winch can be operated both manually and automatically and comes equipped with a working light and a heated rear camera for the best possible visibility. Even when reverse operating with the winch, the driver retains a clear view, allowing him to immediately assess the quality of the slopes. The cable drum is operated by a hydraulic motor and a planetary gear. If desired, the cable can be uncoiled using the ROLL OUT system or manually with a pulling force of 180 N (18.35 kg/40.47 lbf).

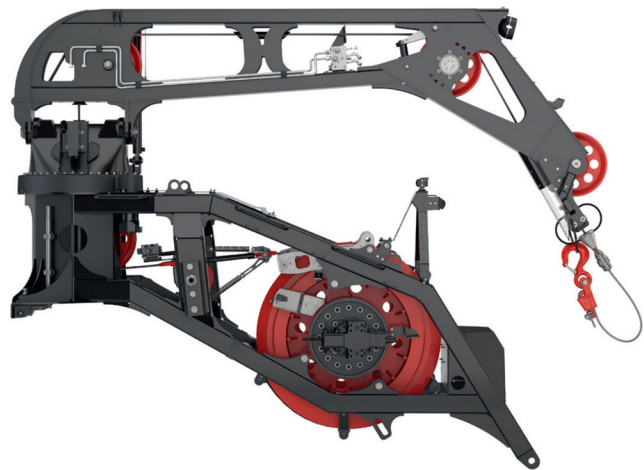

TECHNICAL DATA

Maximum winch pulling force	44.1 kN/4.5 t
WINCONTROL	auto/eco/manual mode
Maximum cable length	1,200 m (1,312 yd)
Cable diameter	11 mm (0.43 in)
Cable breaking strain	150 kN
Full pulling force (on vehicle longitudinal axis)	+/-35°
Constant pulling force across all cable lengths	
Continuous lateral pulling force reduction	
Winch pivot point adapted to the center of gravity machine	

STRONG EQUIPMENT

The AUTOMATIC winch has a pulling force of up to 4.5 tons. Additionally, the two selectable Wincontrol functions offer: Automatic control with up to 44.1 kN/4.5 tons of pulling force or eco mode with a restricted pulling force of up to 34.3 kN/3.5 tons. This force is distributed between the winch and the traction drive and provides a gentle interface with the machine as well as fuel savings. Additionally, in automatic mode the driver can select from one of three different types of control: *soft*, *medium* and *dynamic*. Manual control can be initiated once more at the touch of a button.

FOR MORE INFORMATION:

prinoth@prinoth.com · www.prinoth.com

Prinoth[®]