

X BLADE

FOR PERFECT PARKS

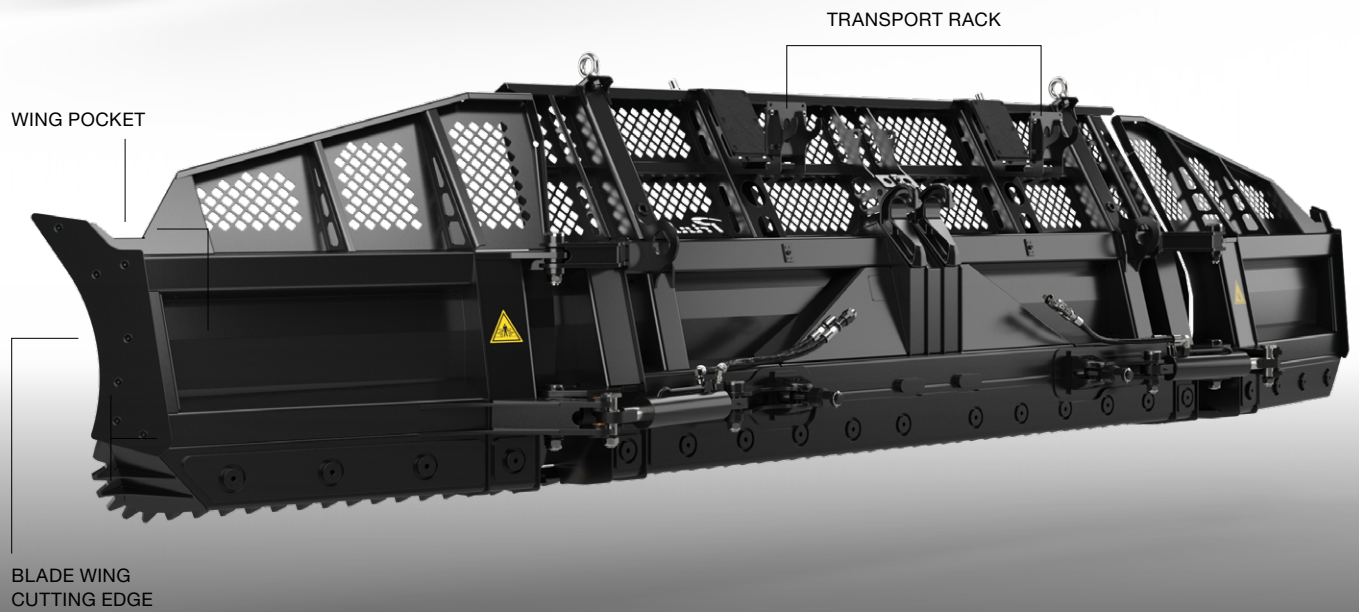

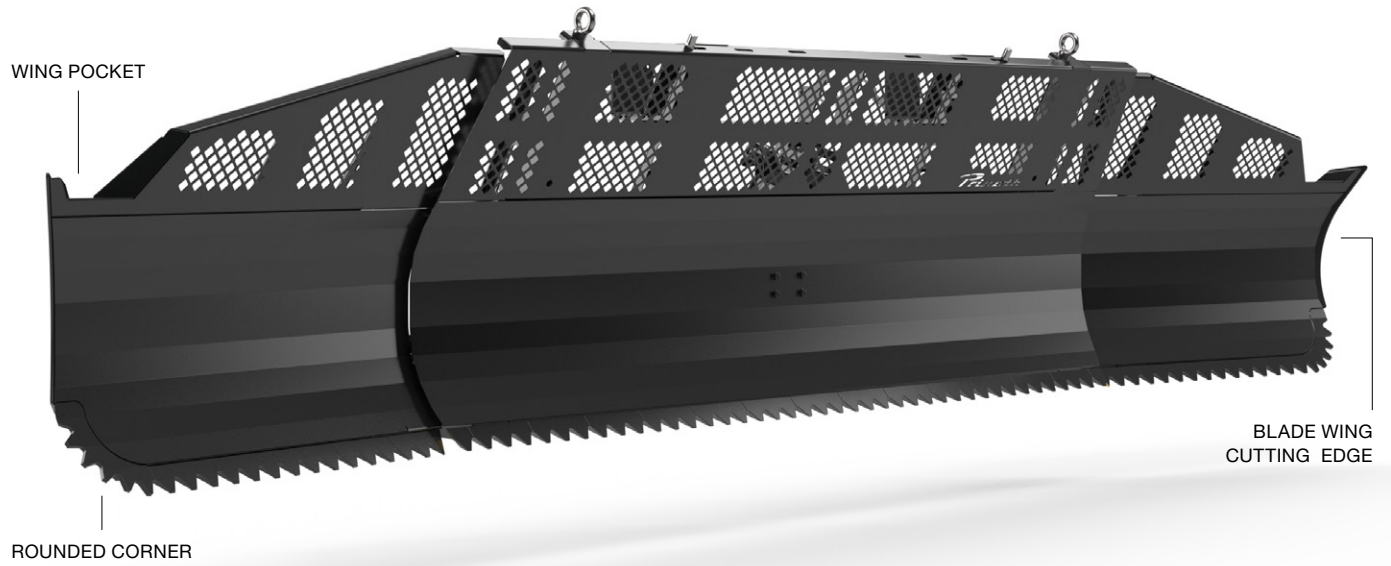
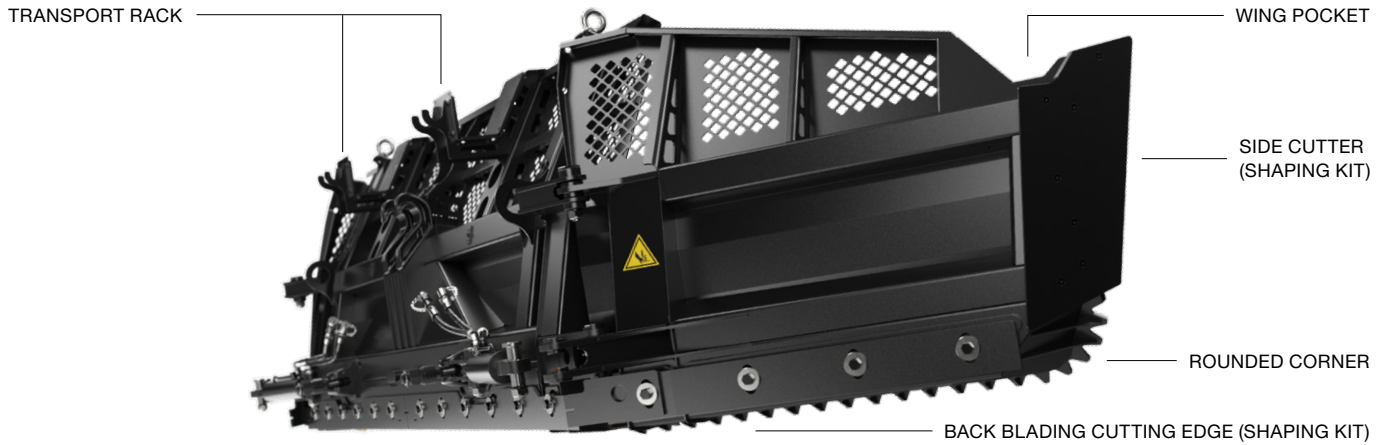

X BLADE

BUILT TO BUILD PARKS

The X Blade is optimized to save time and work efficiently in the park, making it the tool of choice for the world's best Terrain Park builders. The new blade wings make shaping features, matching passes and cutting straight edges easier than ever before, whether you're a seasoned veteran or just starting out. The design enhances precision while providing power needed for the toughest conditions.

FOR SAVING TIME

The following features make park building more efficient, reducing the need for hand-work:

The blade wing cutting edge

- Cuts cleanly with the blade wings when moving both forward and backward due to beveled edges on the front and back
- Gives the wings better reach for cutting or moving snow around features while keeping distance from the tracks

Rounded corners with forged teeth

- Processes snow and ice while moving large snow piles
- Cuts and plows with smooth engagement
- Is optimized for working with transitions such as pipe floors, hip landings, and jump take-offs
- Makes matching passes easier and reduces blade-dives

Optimum blade radius

- Rolls the snow smoothly, preventing it from spilling over the top or sides of the blade
- Shifts large snow masses easily

FOR EASY TOOL TRANSPORTATION

To ensure that all tools for park construction are close at hand, they can be transported safely and easily with the X Blade:

Reinforced upper snow screen and fully boxed wing pockets

- Gets under jibs, rails, snow guns and water hoses

- Provides strength for over-the-blade forks and working with constructed features such as rails and boxes

Adjustable pins, tie-down points, optional towing hook

- Keeps forks or snow guns centered on the blade
- Provides places to hook ratchet straps and other tie-downs
- Pulls loads up to 1,000 kg/2,200 lb with the optional towing hook

Transport rack

- Transports shaping tools, signs, snowboards or skis conveniently on the blade

SHAPING KIT (OPTIONAL)

Side cutter with or without angle support

Executes smooth cuts with 20 mm thick beveled cutting edges

Cuts cleanly at any wing angle

Easily removable and replaceable

Creates a blade that is significantly wider than the tracks

Back blading cutting edge

Cuts quickly and cleanly with the length of the entire blade

Cuts jumps and landings evenly

Shapes an even surface when going backwards

COMPATIBLE VEHICLES

BISON X (GENERATION BO)

LEITWOLF X (GENERATION LT, LIT, LI, LE)

TECHNICAL DATA

Blade width with side wings closed	15'2" 4,627 mm
Blade width with side wings open (without shaping kit)	18'10" 5,751 mm
Blade width with side wings open (with shaping kit)	19'1" 5,818 mm

FOR MORE INFORMATION

prinoth@prinoth.com · sg.prinoth.com

Prinoth[®]